



## **Indoor 1550nm Fiber Amplifier**

**OP-EV1115 -Splitter &OP-EV1215 -Splitter (adjustable) Series**



**Shenzhen Optostar Optoelectronics Co., Ltd**

**2016. 5 (Version 1)**

## 1. Summary

- OP-EV1115-Splitter Series 1550nm CATV EDFA is an important Optical Relay Transmission Equipment of 1550nm Optical Fiber Communication System. It is mainly used in long-distance optical fiber transmission of television image signal, digital television signal, telephone voice signal data (or compressed Data) Signal.
- Low-noise Pump Laser of famous brand, imported high performance Erbium-doped Fiber, perfect and Microcomputer Automatic Controlled System are built in the OP-EV1115 -Splitter Series 1550nm CATV EDFA to ensure the excellent performance.
- We developed different types in order to apply to a variety of engineering environments; We also developed a wild-type model that fit for the ambient temperature from-40 °C to +60 °C .
- The out-look of OP-EV1115 -Splitter Series 1550nm CATV EDFA is beautiful. It's technical index of performance and advanced of technology are comparable with the same import types. It can meet the different engineering application of the user because of its easy installation and high cost performance. So that ,it's the best choose to build a Large or medium-sized.

## 2. Performance Characteristics

- Use low-noise pump laser of famous brand with low distortion, wide bandwidth and high output optical power.
- Use high performance erbium-doped fiber, with high energy conversion efficiency; Advanced SMT production process with higher reliability is used in the internal circuitry.
- Built-in perfect microcomputer automatic control circuit, monitor a variety of working conditions of output power and laser in real time, to make sure the optical output power is steady and extend the working life of the laser.
- Blue VFD Display displaying the operating parameters and fault information accurately and GB Class II Transponder monitoring the network by Ethernet are built in 19"1U High-standard Rack.
- Large cast aluminium drain case and high-frequency E-Electric refrigerator witch make the equipment can adapt to field environmental temperature about from -40 °C to +60 °C are build in the wild-type EDFA. It is mainly used in remote areas having no indoor room.

### 3. Technique Parameters

Items	Unit	Technique Parameter	
Working Bandwidth	nm	1535 ~1565	
Input Optical Power Range	dBm	-3~+10	
Output Optical Power	dBm	13 ~24	
Output Power Stability	dB	±0.5	
Noise Figure(When the Input Optical Power is 0dB )	dB	≤ 5.0	
Return Loss	Input Port	dB	≥ 45
	Output Port	dB	≥ 45
Pump Leakage Power	Input Port	dBm	≤ -30
	Output Port	dBm	≤ -30
C/N	dB	≥ 51	
C/CTB	dB	≥ 63	
C/CSO	dB	≥ 63	
Optical Connector Type		FC/APC 或 SC/APC	
Power Voltage	V	AC 160V~250V (50 Hz)	
Working Temperature Range	°C	Indoor: -5~+55; Outdoor: -40~+65	
Max Working Relative Humidity	%	Max. 95%no condensation	
Storage Temperature Range	°C	-30 ~+70	
Max Storage Relative Humidity	%	Max. 95%no condensation	
Overall Dimension	mm	Indoor: 483 (L) X 380 (W) X 44 (H)	

★Special Notice:

The performance parameters of this manual according to GY/T 143-2000 <Specifications and methods of measurement on AM optical transmitter and receiver used in CATV system> .We get it under the following testing environment.

★Testing Environment:

Together with Standard 1550nm External Modulation Optical Transmitter, 10km standard optical fiber and optical passive attenuator make the testing circuit .Set with 59PAL-Danalog TV channel signal at range of 550MHZ in the fix index loss of circuit, transmit digital TV signal at rang of 550MHZ~862MHZ, the electricity (8 MHZ bandwidth) digital signal is 10dB lower than analog signal of carrier electricity level. When the input of optical receiver is -1dBm, measure C/CTB, C/CSO, C/N.

#### 4. Block Diagram

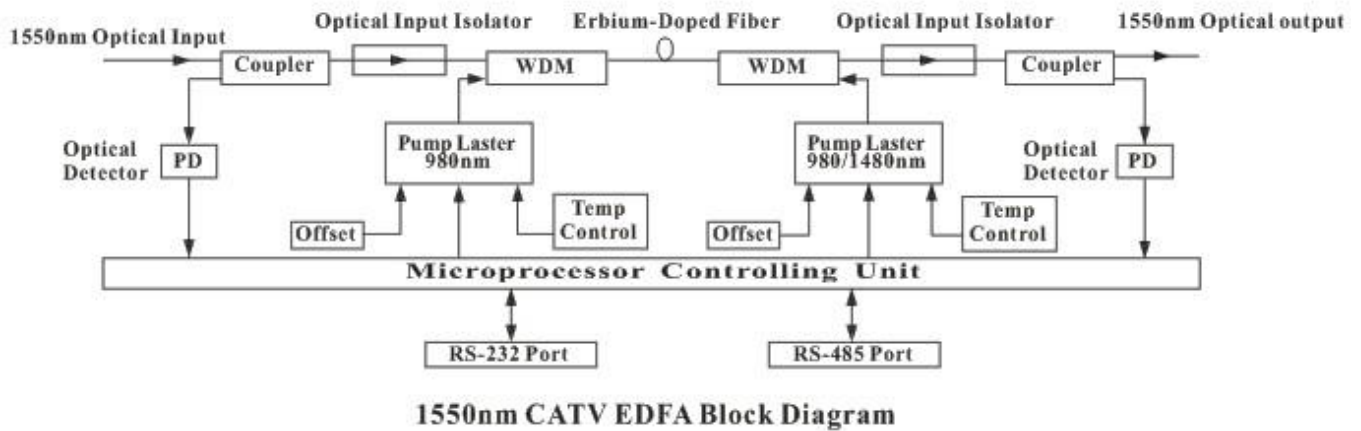

#### 5. Model to Recommend:

**OP-EV1215 -Splitter** model is a product with adjustable output power. The max output power is up to 24dBm, and can be adjusted within 0-3dB with stepping of 0.1dBm.

## Contact OPTOSTAR

### Shenzhen Optostar Optoelectronics Co., Ltd

Address:A-14,Haide Building,the Intersection of Nanxin Road and Haide Second Road Nansha n District Shenzhen,China .

Tel: +86-755-26400198 +86-755-26400288 Fax: +86-755-26411001

Email: [info@optostar.com.cn](mailto:info@optostar.com.cn)

Skype:ouyangroya

Web: [www.optostar.com.cn](http://www.optostar.com.cn)